

Chillers

Dados comerciais e técnicos

Chiller de condensação a água sem condensador

- » Grande intervalo de capacidade
(330 kW – 1.400 kW)
- » Instalações interiores
- » Design compacto
- » Circuitos de refrigeração independentes com compressor de mono parafuso
- » Fornecimento de água até -8 °C (opcional)
- » Novo controlador MicroTech III



ECDPT11-425

EWLD-I-
330~1.400 kW

R-134a



Daikin Europe N.V.

Acerca da Daikin

A Daikin possui uma reputação mundial com base em mais de 85 anos de experiência como fabricante bem sucedido de equipamento de ar condicionado de alta qualidade para utilização industrial, comercial e residencial. A qualidade bastante invejada da Daikin provém muito simplesmente da grande atenção dedicada ao planeamento, produção e testes assim como à assistência pós-venda. Para tal, cada componente é cuidadosamente seleccionado e rigorosamente testado para determinar a sua mais valia para a qualidade e fiabilidade do produto.

Nova gama de chillers de condensação a água EWLD-I- da Daikin com controlador melhorado

De forma a melhorar o portfólio de chillers com uma lógica de controlo superior, a Daikin destaca hoje a série EWLD-I- com condensador remoto, que incorpora o novo controlador MicroTech III.

O MicroTech III assegura máxima eficiência e fiabilidade, condições de funcionamento estáveis e protecção dos componentes críticos.

A nova gama é composta por 19 tamanhos, e está disponível na versão de eficiência padrão. Cada unidade está equipada com um, dois ou três circuitos de refrigeração R-134a, que dispõem de um evaporador "shell & tube" e compressores mono parafuso com controlo da capacidade de regulação contínua, que permite à unidade modular a sua capacidade de 100% até 8,33%.

Além disso, a gama dispõe de uma vasta lista de opções, incluindo a versão de baixa temperatura da água de saída, para fornecimento de água até -8 °C.



Índice

FUNCIONALIDADES DA UNIDADE	4
DADOS TÉCNICOS	5
1. Features and advantages	5
2. General Characteristics	8
3. Technical and Electrical Specifications	12
4. Nomenclature	15
5. Capacity Tables	16
6. Dimensional drawings	20
7. Sound data	22
8. Installation	24
9. Operation range	25
10. Hydraulic performance	30
11. Specification text	31



Funcionalidades da unidade

Flexibilidade de aplicação

A série EWLD-I- está disponível numa vasta gama de capacidades (330 - 1,400 kW), permitindo soluções de projecto para uma ampla gama de aplicações.

As peças que requerem trabalhos mais frequentes permitem um acesso simples, simplificando os trabalhos de manutenção e assistência. Além disso, as novas unidades permitem uma integração flexível numa vasta gama de sistemas de controlo e gestão de edifícios.

Grande limite de funcionamento

A opção 'água gelada' permite à nova gama fornecer água até -8°C , tornando as unidades adequadas para algumas aplicações industriais típicas.

Design compacto

A série EWLD-I- dispõe de design compacto, e é ideal para a substituição ou reequipamento simples, ou para novas construções.

Lógica de controlo superior

O novo controlador MicroTech III disponibiliza um controlo de fácil utilização. A lógica do controlo foi concebida para fornecer máxima eficiência, permitir o funcionamento em condições de funcionamento invulgares, e fornecer um histórico do funcionamento da unidade. Uma das maiores vantagens é a interface simples com comunicações Lonwork, BACnet, Ethernet TCP/IP ou Modbus.

Vasta lista de opções

O modelo base inclui várias opções de série, montadas de fábrica, tais como: válvula de expansão electrónica, monitor de fases, arrancador estrela-triângulo, etc. Além disso, a nova gama conta com uma vasta lista de opções, incluindo a versão de água gelada, arrancador suave, contador de energia, etc.

1 Features

- Cooling range: 328–1,422kW
- EER range: 3.51 to 3.91
- Stepless single-screw compressor
- Optimised for use with R-134a
- Standard electronic expansion valve
- DX shell and tube evaporator – one pass refrigerant side for easy oil circulation and return
- All models are PED pressure vessel approved

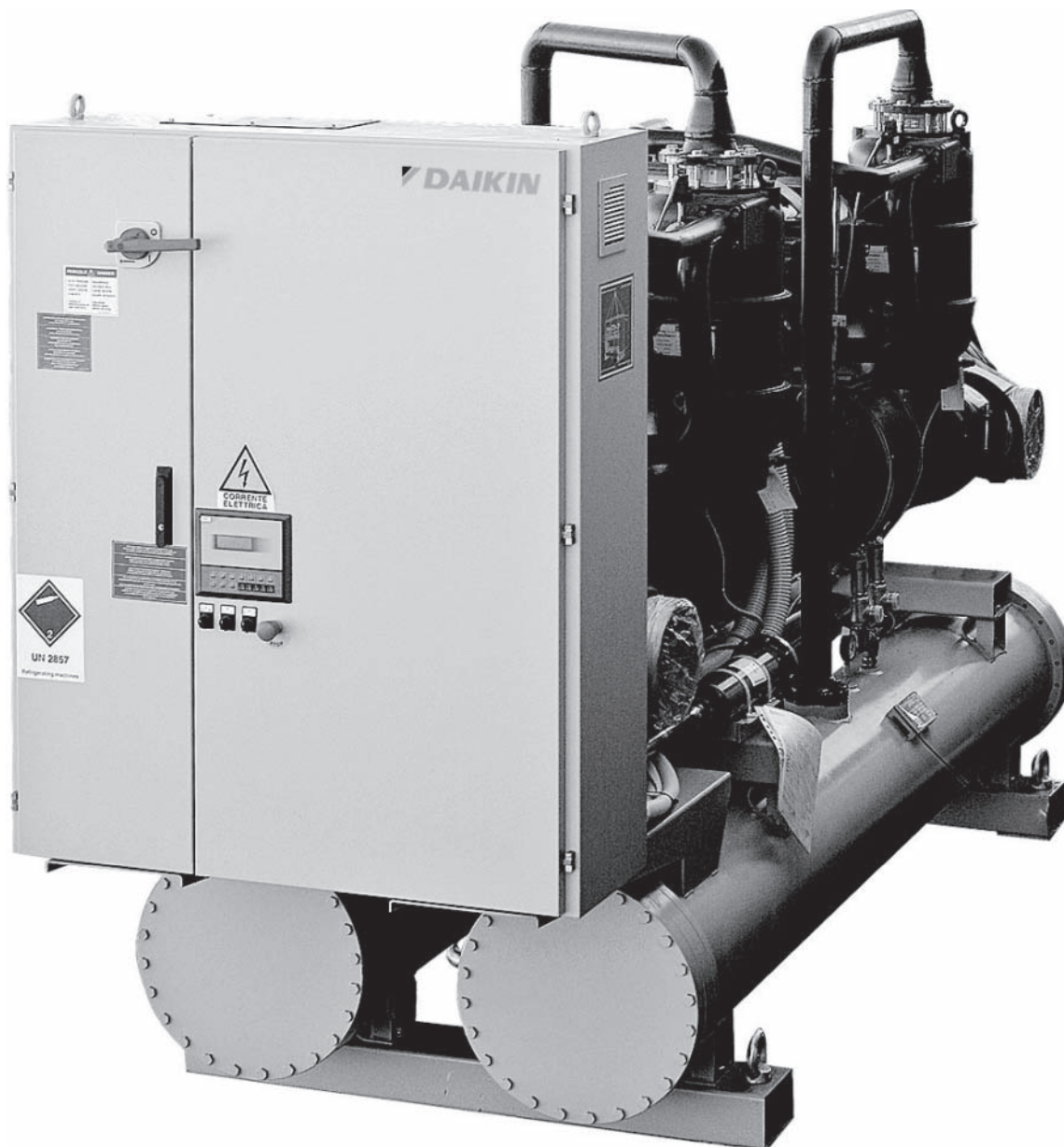

1 Features

Features and advantages

The EWLD~I- chillers, featuring 1, 2 or 3 single screw compressors, are manufactured to satisfy the requirements of the consultants and the end user. Units are designed to minimise energy costs while maximising the refrigeration capacities. Daikin's chiller design experience combined with outstanding features makes the EWLD~I- chiller unmatched in the industry.

Seasonal quietness

The compressor design with a single screw and twin rotors allows a constant gas flow. This compression process completely eliminates gas pulsations. The oil injection also results in significant mechanical noise reduction.

The twin gas compressor discharge chambers are designed to act as attenuators, based on the harmonic wave principle with destructive interference, thus always resulting equal to zero. The extremely low noise compressor performance affords the use of EWLD~I- chiller for all applications.

The reduced number of vibrations produced from the EWLD~I- chiller offers a surprisingly quiet operation eliminating the noise transmission through the structure and the chilled water piping system.

Ininitely capacity control

Cooling capacity control is infinitely variable by means of a screw compressor controlled by microprocessor system. Each unit has infinitely variable capacity control from 100% down to 25% (one compressor unit), down to 12.5% (two compressors units) and down to 8.3% (three compressors units). This modulation allows the compressor capacity to exactly match the building cooling load without any leaving evaporator water temperature fluctuation. This chilled water temperature fluctuation is avoided only with a stepless control.

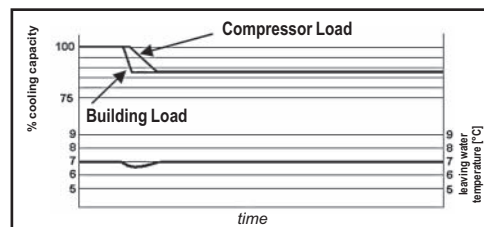

EWLT fluctuation with stepless capacity control

With a compressor load step control in fact, the compressor capacity, at partial loads, will be too high or too low compared to the building cooling load. The result is an increase in chiller energy costs, particularly at the part-load conditions at which the chiller operates most of the time.

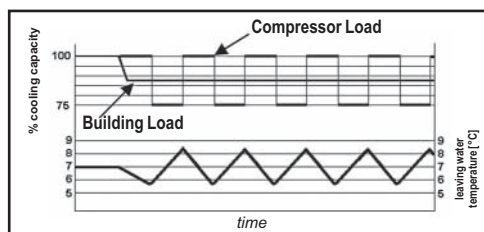

ELWT fluctuation with steps capacity control (4 steps)

Units with stepless regulation offer benefits that the units with step regulation are unable to match. The ability to follow the system energy demand at any time and the possibility to provide steady outlet water temperature without deviations from the set-point, are the two points that allow you to understand how the optimum operating conditions of a system can be met only through the use of a unit with stepless regulation.

Code requirements – Safety and observant of laws/directives

All water cooled units are designed and manufactured in accordance with applicable selections of the following:

Construction of pressure vessel	97/23/EC (PED)
Machinery Directive	2006/42/EC
Low Voltage	2006/95/EC
Electromagnetic Compatibility	2004/108/EC
Electrical & Safety codes	EN 60204-1 / EN 60335-2-40
Manufacturing Quality Stds	UNI – EN ISO 9001:2004

1 Features

Certifications

All units manufactured are CE marked, complying with European directives in force, concerning manufacturing and safety. On request units can be produced complying with laws in force in non European countries (ASME, GOST, etc.), and with other applications, such as naval (RINA, etc.).

Versions

EWLD~I- is available in standard efficiency level:

S: Standard Efficiency

19 sizes, covering a cooling capacity range from 328 up to 1422 kW, EER up to 3.91

The EER (Energy Efficiency Ratio) is the ratio of the Cooling Capacity to the Power Input of the unit. The Power Input includes: the power input for operation of the compressor, the power input of all control and safety devices.

Sound Configuration

EWLD~I- is available in standard sound level configuration:

S: Standard Sound

2 General Characteristics

General characteristics

Cabinet and structure

The cabinet is made of galvanized steel sheet and painted to provide a high resistance to corrosion. Colour Ivory White (Munsell code 5Y7.5/1) (\pm RAL7044). The base frame has eye-hook for lifting the unit with ropes for an easy installation. The weight is uniformly distributed along the profiles of the base and this facilitates the arrangement of the unit.

Screw compressors

The single-screw compressor has a well balanced compression mechanism which cancels the screw rotor load in both the radial and axial directions. Inherent to the basic single-screw compressor design is the virtually load-free operation that gives main bearing design life of 3-4 times greater than twin-screws, and eliminates expensive and complicated thrust balancing schemes. The two exactly opposed gate rotors create two exactly opposed compression cycles. Compression is made at the lower and upper parts of the screw rotor at the same time, thus cancelling the radial loads. Also, both ends of the screw rotor are subjected to suction pressure only, which cancels the axial loads and eliminates the huge thrust loads inherent in twin-screw compressors.

Oil injection is used for these compressors in order to get EER at high condensing pressure. EWLD~I- units are provided with a high efficiency oil separator to maximise oil extraction.

Compressors have an infinitely variable capacity control down to 25% of its total capacity. This control is made by means of capacity slides controlled by microprocessors.

Standard start is star-delta type; soft start type is available as option.

Ecological R-134a refrigerant

The compressors have been designed to operate with R-134a, ecological refrigerant with zero ODP (Ozone Depletion Potential) and very low GWP (Global Warming Potential) that means low TEWI (Total Equivalent Warming Impact).

Evaporator

The units are equipped with a Direct Expansion shell&tube evaporator with copper tubes rolled into steel tubesheets. The evaporators are single-pass on both the refrigerant and water sides for pure counter-flow heat exchange and low refrigerant pressure drops. Both attributes contribute to the heat exchanger effectiveness and total unit's outstanding efficiency.

The external shell is covered with a 10mm closed cell insulation material. Each evaporator has 1 circuit for each compressor and is manufactured in accordance to PED approval. The evaporator water outlet connections are provided with Victaulic Kit (as standard).

Electronic expansion valve

The unit is equipped with the most advanced electronic expansion valves to achieve precise control of refrigerant mass flow. As today's system requires improved energy efficiency, tighter temperature control, wider range of operating conditions and incorporate features like remote monitoring and diagnostics, the application of electronic expansion valves becomes mandatory. Electronic expansion valve proposes features that make it unique: short opening and closing time, high resolution, positive shut-off function to eliminate use of additional solenoid valve, highly linear flow capacity, continuous modulation of mass flow without stress in the refrigerant circuit and corrosion resistance stainless steel body.

EEXV strength point is the capacity to work with lower ΔP between high and low pressure side, than a thermostatic expansion valve. The electronic expansion valve allows the system to work with low condenser pressure (winter time) without any refrigerant flow problems and with a perfect chilled water leaving temperature control.

Refrigerant Circuit

Each unit has independent refrigerant circuits and each one includes:

- Single screw compressor with external cyclonic oil separator
- Evaporator
- Oil pressure transducer
- High pressure switches
- High pressure transducer
- Low pressure transducer
- Moisture liquid indicator

2 General Characteristics

- High efficiency oil separator
- Replaceable core filter-drier
- Electronic expansion valve

Electrical control panel

Power and control are located in the main panel that is manufactured to ensure protection against all weather conditions. The electrical panel is IP54 and (when opening the doors) internally protected with Plexiglas panel against possible accidental contact with electrical components (IP20). The main panel is fitted with a main switch interlocked door.

Power Section

The power section includes compressors fuses and control circuit transformer.

MicroTech III controller

MicroTech III controller is installed as standard; it can be used to modify unit set-points and check control parameters. A built-in display shows chiller operating status plus temperatures and pressures of water, refrigerant, programmable values, set-points. A sophisticated software with predictive logic, selects the most energy efficient combination of compressors and EEXV to keep stable operating conditions to maximise chiller energy efficiency and reliability.

MicroTech III is able to protect critical components based on external signs from its system (such as motor temperatures, refrigerant gas and oil pressures, correct phase sequence, pressure switches and evaporator). The input coming from the high pressure switch cuts all digital output from the controller in less than 50ms, this is an additional security for the equipment.

Fast program cycle (200ms) for a precise monitoring of the system. Floating point calculations supported for increased accuracy in P/T conversions.

Control section - main features

- Management of the compressor stepless capacity.
- Chiller enabled to work in partial failure condition.
- Full routine operation at condition of:
 - high ambient temperature value
 - high thermal load
 - high evaporator entering water temperature (start-up)
- Display of evaporator entering/leaving water temperatures.
- Display of condensing-evaporating temperatures and pressures, suction and discharge superheat for each circuit.
- Leaving water evaporator temperature regulation. Temperature tolerance = 0.1°C.
- Compressor and evaporator pumps hour counters.
- Display of Status Safety Devices.
- Number of starts and compressor working hours.
- Optimized management of compressor load.
- Re-start in case of power failure (automatic / manual).
- Soft Load (optimized management of the compressor load during the start-up).
- Start at high evaporator water temperature.
- Return Reset (Set Point Reset based on return water temperature).
- Set point Reset (optional).
- Application and system upgrade with commercial SD cards.
- Ethernet port for remote or local servicing using standard web browsers.
- Two different sets of default parameters could be stored for easy restore.

Safety device / logic for each refrigerant circuit

- High pressure (pressure switch).
- High pressure (transducer).

2 General Characteristics

- Low pressure (transducer).
- High compressor discharge temperature.
- High motor winding temperature.
- Phase Monitor.
- Low pressure ratio.
- High oil pressure drop
- Low oil pressure.
- No pressure change at start.

System security

- Phase monitor.
- Low Ambient temperature lock-out.
- Freeze protection.

Regulation type

Proportional + integral + derivative regulation on the evaporator leaving water output probe.

MicroTech III

MicroTech III built-in terminal has the following features.

- 164x44 dots liquid crystal display with white back lighting. Supports Unicode fonts for multi-lingual.
- Key-pad consisting of 3 keys.
- Push'n'Roll control for an increased usability.
- Memory to protect the data.
- General faults alarm relays.
- Password access to modify the setting.
- Application security to prevent application tampering or hardware usability with third party applications.
- Service report displaying all running hours and general conditions.
- Alarm history memory to allow an easy fault analysis.

Supervising systems (on request)

MicroTech III remote control

MicroTech III is able to communicate to BMS (Building Management System) based on the most common protocols as:

- ModbusRTU
- LonWorks, now also based on the international 8040 Standard Chiller Profile and LonMark Technology
- BacNet BTP certified over IP and MS/TP (class 4) (Native)

Chiller Sequencing

MicroTech III controller allows an easy plug-in sequencing technology based on digital or serial panel.

Digital Sequencing Panel

This panel is basically a step inserter that switches ON/OFF up to 11 units (chillers or heat pumps operating in the same cooling/heating mode) depending on the selected set point; the units are connected with the panel through standard cables and no serial card is requested.

Serial Sequencing Panel

Basically this panel sequences a chiller plant by switching on/off the units (up to 7 chillers) taking into account their running hours and the requested plant load, in order to optimise the number of working units for each condition; serial cards and shielded cables are requested to connect the panel with the units and, if installed, a BMS.

2 General Characteristics

Standard accessories (supplied on basic unit)

Evaporator Victaulic Kit - Hydraulic joint with gasket for an easy and quick water connection.

Evaporator Water side design pressure 10 bar

Y-D starter - Star Delta starter is the standard type

Double set-point - Dual leaving water temperature set-points.

Phase monitor - The phase monitor controls that phases sequence is correct and controls phase loss.

High Pressure Side Manometers

Hour Run meter - Digital compressors hour run meter

General fault contactor - Contactor for alarm warning.

Set-point reset, demand limit and alarm from external device - The leaving water temperature set-point can be overwritten with the following options: 4-20mA from external source (by user); outside ambient temperature; evaporator water temperature Δt . Moreover the device allow the user to limit the load of the unit by 4-20mA signal or by network system and the microprocessor is able to receive an alarm signal from an external device (pump etc... - user can decide if this alarm signal will stop or not the unit).

Electronic Expansion Valve

Options (on request)

Brine version - Allows the unit to operate down to -8°C leaving liquid temperature (antifreeze required).

Liquid Receiver - the receiver capacity is 170 Lt

20mm Evaporator Insulation

Suction line shut-off valve - Suction shut-off valve installed on the suction of the compressor to facilitate maintenance operation.

Discharge line shut-off valves - Discharge shut-off valve installed on the discharge of the compressor to facilitate maintenance operations.

Sound Proof System - Made of sheet metal and internally insulated, the cabinet is "integral kind" (around the whole chiller, not only around the compressors) to reach the best performance in noise reduction.

Dual Pressure Relief Valve on evaporator

Soft start - Electronic starting device to reduce the mechanical stress during compressor start-up

Compressor thermal overload relays - Safety devices against compressor motor overloading in addition to the normal protection envisaged by the electrical windings.

Under/Over Voltage - This device controls the voltage value of power supply and stops the chiller if the value exceeds the allowed operating limits.

Energy Meter - This device allows to measure the energy absorbed by the chiller during its life. It is installed inside the control box mounted on a DIN rail and show on a digital display: Line-to-Line Voltage, Phase and Average Current, Active and Reactive Power, Active Energy, Frequency.

Evaporator flow switch for the water piping

Rubber type antivibration mounts - Supplied separately, these are positioned under the base of the unit during installation. Ideal to reduce the vibrations when the unit is floor mounted.

Witness test - Every unit is always tested at the test bench prior to the shipment. On request, a second test can be carried out, at customer's presence, in accordance with the procedures indicated on the test form. (Not available for units with glycol mixtures).

Container kit

Acoustic test

3 Specifications

3-1 Technical Specifications				EWLD320I-SS	EWLD400I-SS	EWLD420I-SS	EWLD500I-SS	EWLD600I-SS	EWLD650I-SS	EWLD750I-SS	EWLD800I-SS	EWLD850I-SS	EWLD900I-SS	
Cooling capacity	Nom.		kW	328 (1)	391 (1)	428 (1)	504 (1)	596 (1)	657 (1)	730 (1)	788 (1)	850 (1)	919 (1)	
Capacity control	Method	Stepless												
	Minimum capacity		%	25				12.5						
Power input	Cooling	Nom.	kW	83.8 (1)	100 (1)	116 (1)	137 (1)	165 (1)	181 (1)	198 (1)	214 (1)	231 (1)	252 (1)	
EER				3.91 (1)	3.9 (1)	3.7 (1)	3.67 (1)	3.61 (1)	3.63 (1)	3.69 (1)	3.67 (1)		3.65 (1)	
Casing	Colour	Ivory white												
	Material	Galvanized and painted steel sheet												
Dimensions	Unit	Height	mm	1,899				2,325						
		Width	mm	1,464										
		Depth	mm	3,114				4,391						
Weight	Unit			kg	1,861	1,869	1,884	3,331	3,339	3,347	3,356	3,364	3,412	
	Operation weight			kg	2,054	2,052	2,056	3,602	3,603	3,604	3,605	3,645		
Water heat exchanger - evaporator	Water volume			l	193	183	172	271	263	256	248	241	233	
	Water flow rate	Nom.	l/min	940.2	1,120.8	1,227.0	1,444.8	1,708.8	1,883.4	2,092.8	2,259.0	2,436.6	2,634.6	
	Nominal water pressure drop	Cooling	Total	kPa	34	47	54	49	39	52	47		45	
		Insulation material			Closed cell									
	Type			Single pass shell and tube										
Sound power level	Cooling	Nom.	dBA	93.7	96.6	96.7	96.9	97.3	97.8	98.9	99.8			
Sound pressure level	Cooling	Nom.	dBA	75.2	76.2	78.2	77.8	78.2	78.7	79.8	80.7			
Compressor	Type			Semi-hermetic single screw compressor										
	Quantity			1				2						
	Oil	Charged volume		l	16				32					
Operation range	Evaporator	Cooling	Min.	°CDB	-8									
			Max.	°CDB	15									
	Condenser	Cooling	Min.	°CDB	25									
			Max.	°CDB	60									
Refrigerant	Type			R-134a										
	Charge			kg	5									
	Circuits	Quantity		1								2		
Piping connections	Liquid line connection		mm	42										
	Discharge line connection		mm	88.9										
	Evaporator water inlet/outlet			168.3mm										
Safety devices	Item	01	High discharge pressure (pressure switch)											
		02	High discharge pressure (pressure transducer)											
		03	Low suction pressure (pressure transducer)											
		04	Compressor motor protection											
		05	High discharge temperature											
		06	Low oil pressure											
		07	Low pressure ratio											
		08	High oil filter pressure drop											
		09	Phase monitor											
		10	Emergency stop button											
		11	Water freeze protection controller											

3-2 Technical Specifications				EWLD950I-SS	EWLD10I-SS	EWLDC11I-SS	EWLDC12I-SS	EWLDC13I-SS	EWLDC14I-SS	EWLDC15I-SS	EWLDC16I-SS	EWLDC17I-SS
Cooling capacity	Nom.		kW	966 (1)	1,033 (1)	1,078 (1)	1,125 (1)	1,188 (1)	1,267 (1)	1,319 (1)	1,370 (1)	1,422 (1)
Capacity control	Method	Stepless										
	Minimum capacity		%	12.5	8.3							
Power input	Cooling	Nom.	kW	271 (1)	279 (1)	296 (1)	312 (1)	329 (1)	347 (1)	366 (1)	386 (1)	405 (1)
EER				3.56 (1)	3.59 (1)	3.64 (1)	3.60 (1)	3.61 (1)	3.65 (1)	3.60 (1)	3.55 (1)	3.51 (1)
Casing	Colour	Ivory white										
	Material	Galvanized and painted steel sheet										
Dimensions	Unit	Height	mm	2,325	2,415							
		Width	mm	1,464	2,135							
		Depth	mm	4,391	4,426							
Weight	Unit			kg	3,412	5,146	5,167	5,188	5,208			
	Operation weight			kg	3,645	5,667	5,671	5,677	5,680			

3 Specifications

3-2 Technical Specifications				EWLD950I-SS	EWLDC10I-SS	EWLDC11I-SS	EWLDC12I-SS	EWLDC13I-SS	EWLDC14I-SS	EWLDC15I-SS	EWLDC16I-SS	EWLDC17I-SS	
Water heat exchanger - evaporator	Water volume		l	233	504			489	472	504		489	472
	Water flow rate	Nom.	l/min	2,769.0	2,961.0	3,090.0	3,225.0	3,405.6	3,631.8	3,781.2	3,927.6	4,076.4	
	Nominal water pressure drop	Cooling	Total	kPa	45	52	46	49	41	51	55	59	63
		Insulation material			Closed cell								
	Type			Single pass shell and tube									
Sound power level	Cooling	Nom.	dBA	99.8	100.4	100.8	101.2	103	100.4	100.8	101.2	103	
Sound pressure level	Cooling	Nom.	dBA	80.7	80.4	80.8	81.2	83	80.4	80.8	81.2	83	
Compressor	Type			Semi-hermetic single screw compressor									
	Quantity			2	3								
	Oil	Charged volume		l	32	48							
Operation range	Evaporator	Cooling	Min.	°CDB	-8								
			Max.	°CDB	15								
	Condenser	Cooling	Min.	°CDB	25								
			Max.	°CDB	60								
Refrigerant	Type			R-134a									
	Charge			kg	5								
	Circuits	Quantity		2	3								
Piping connections	Liquid line connection		mm	42									
	Discharge line connection		mm	88.9									
	Evaporator water inlet/outlet			168.3mm	219.1mm								
Safety devices	Item	01	High discharge pressure (pressure switch)										
		02	High discharge pressure (pressure transducer)										
		03	Low suction pressure (pressure transducer)										
		04	Compressor motor protection										
		05	High discharge temperature										
		06	Low oil pressure										
		07	Low pressure ratio										
		08	High oil filter pressure drop										
		09	Phase monitor										
		10	Emergency stop button										
		11	Water freeze protection controller										

3-3 Electrical Specifications				EWLD320I-SS	EWLD400I-SS	EWLD420I-SS	EWLD500I-SS	EWLD600I-SS	EWLD650I-SS	EWLD750I-SS	EWLD800I-SS	EWLD850I-SS	EWLD900I-SS
Compressor	Phase			3~									
	Voltage			V	400								
	Voltage range	Min.	%	-10									
		Max.	%	10									
	Maximum running current			A	195	242	282	321	195	242	282		
	Starting method			Wye-delta									
Compressor 2	Maximum running current			A	-			195	242	282	321		
Power supply	Phase			3~									
	Frequency			Hz	50								
	Voltage			V	400								
	Voltage range	Min.	%	-10									
		Max.	%	10									
Unit	Maximum starting current			A	330	464			486	620	658	690	721
	Nominal running current (RLA)	Cooling	A	135 (5)	164 (5)	188 (5)	216 (5)	268 (5)	296 (5)	325 (5)	350 (5)	375 (5)	407 (5)
			A	195	242	282	321	390	437	484	524	564	603
	Max unit current for wires sizing			A	215	266	310	353	429	481	532	576	620

3 Specifications

3-4 Electrical Specifications			EWLD950I-SS	EWLDC10I-SS	EWLDC11I-SS	EWLDC12I-SS	EWLDC13I-SS	EWLDC14I-SS	EWLDC15I-SS	EWLDC16I-SS	EWLDC17I-SS	
Compressor	Phase		3~									
	Voltage		V		400							
	Voltage range	Min.	%		-10							
		Max.	%		10							
	Maximum running current		A	321	195	242 282	242 282	282		282 321	282 321	321
Starting method		Wye-delta										
Compressor 2	Maximum running current		A	321	-							
Power supply	Phase		3~									
	Frequency		Hz		50							
	Voltage		V		400							
	Voltage range	Min.	%		-10							
		Max.	%		10							
Unit	Maximum starting current		A	721	814	851.0	883	915		946	978	
	Nominal running current (RLA)	Cooling	A	437 (5)	457 (5)	487 (5)	511 (5)	536 (5)	562 (5)	592 (5)	622 (5)	652 (5)
			A	642	679	726	766.0	806	846	885.0	924	963
	Max unit current for wires sizing		A	706	747	799	843.0	887	931	974.0	1,016	1,059

Notes

- (1)Cooling: entering evaporator water temp. 12°C; leaving evaporator water temp. 7°C; saturated discharge temp. at the compressor 45°C.
- (2)Sound level data are measured at entering evaporator water temp. 12°C; leaving evaporator water temp. 7°C; saturated discharge temp. 45°C; full load operation; standard: ISO3744
- (3)Allowed voltage tolerance ± 10%. Voltage unbalance between phases must be within ± 3%.
- (4)Maximum starting current: starting current of biggest compressor + current of the other compressor at 75 % of maximum load
- (5)Maximum running current is based on max compressor absorbed current in its envelope
- (6)Maximum unit current for wires sizing is based on minimum allowed voltage.
- (7)Maximum current for wires sizing: compressor full load ampere x 1.1

4 Nomenclature

4 - 1 Nomenclature

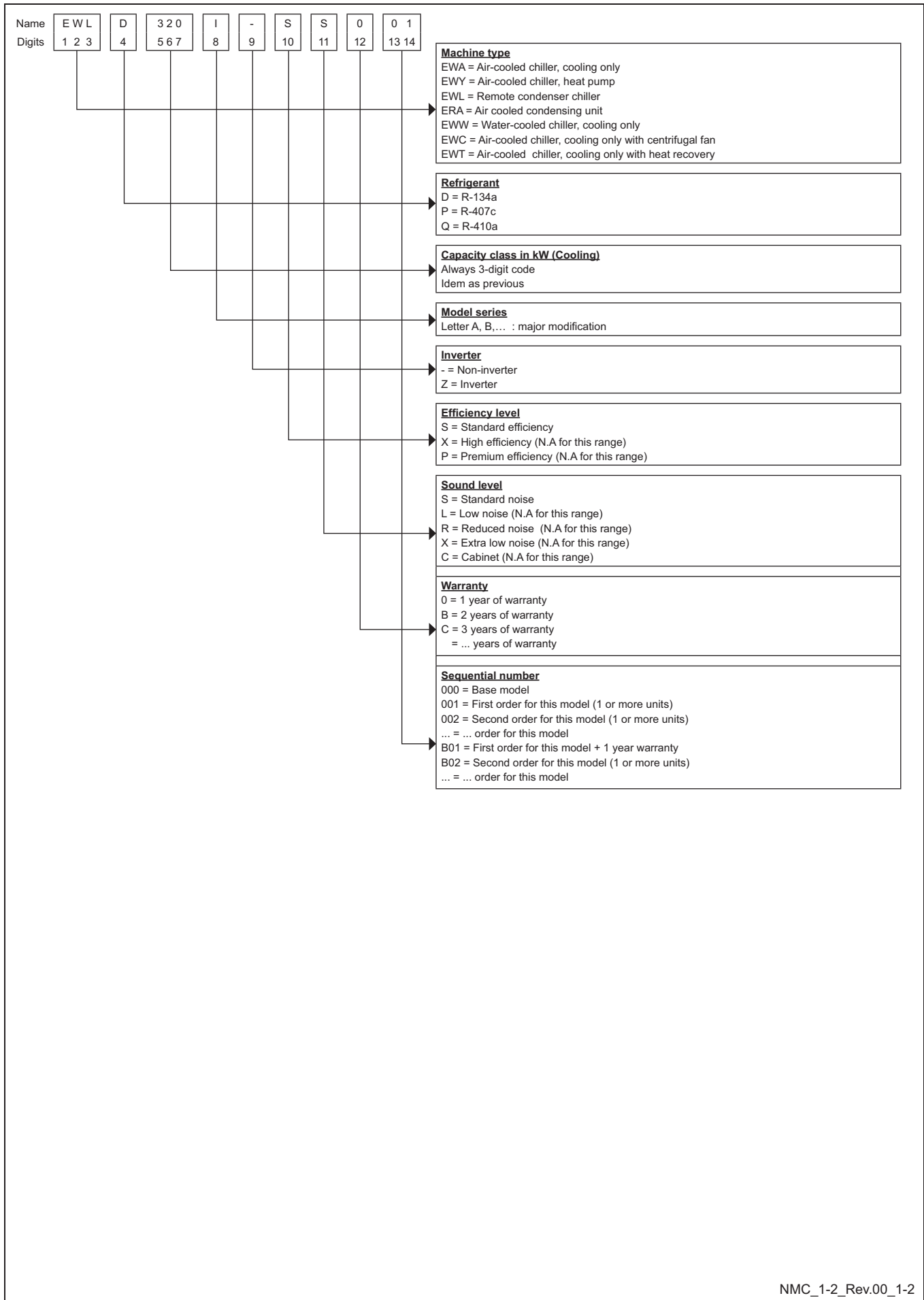

5 Capacity tables

5 - 1 Cooling Capacity Tables

EWLD320~650I-SS

Size	ELWT (°C)	Saturated Discharge Temperature (°C)															
		40			45			50			55			60			
		Cc (kW)	Pi (kW)	Hr (kW)	Cc (kW)	Pi (kW)	Hr (kW)	Cc (kW)	Pi (kW)	Hr (kW)	Cc (kW)	Pi (kW)	Hr (kW)	Cc (kW)	Pi (kW)	Hr (kW)	
320	4	309	74	383	293	83	376	276	92	368	258	103	361	240	116	356	
	5	321	75	396	304	83	387	287	92	379	269	103	372	250	116	366	
	6	333	75	408	316	83	399	298	93	391	279	103	382	260	115	375	
	7	345	76	421	328	84	412	309	93	402	290	103	393	271	115	386	
	8	358	77	435	340	84	424	321	93	414	302	104	406	282	115	397	
	9	371	77	448	352	85	437	333	94	427	313	104	417	293	115	408	
	10	384	80	464	365	88	453	346	97	443	325	107	433	304	119	423	
	11	398	81	479	379	89	467	358	98	456	338	108	445	316	119	435	
	12	412	81	493	392	89	481	372	98	470	350	108	458	328	119	448	
	13	426	82	508	406	90	496	385	99	484	363	109	472	341	120	460	
	14	441	83	524	420	91	511	399	99	498	376	109	486	353	120	473	
	15	456	83	539	435	91	526	413	100	513	390	110	500	366	121	487	
	400	4	369	89	458	349	98	447	329	109	438	309	121	430	287	134	421
		5	383	90	473	363	99	462	342	109	451	321	121	442	299	134	433
		6	397	90	487	377	99	476	356	110	466	334	121	455	311	135	446
7		411	91	502	391	100	491	369	110	479	347	122	469	324	135	459	
8		426	92	518	405	101	506	383	111	494	360	122	482	337	135	472	
9		441	93	534	420	102	522	397	112	509	374	123	497	350	136	486	
10		457	96	553	435	105	540	412	116	528	388	127	515	363	140	503	
11		473	97	570	450	106	557	427	116	543	403	128	530	377	141	518	
12		489	98	587	466	107	573	442	117	559	417	129	546	391	141	533	
13		506	99	604	482	108	590	458	118	576	432	129	562	406	142	548	
14		523	100	622	498	109	607	474	119	593	448	130	578	421	143	563	
15		540	101	640	515	110	625	490	120	610	463	131	594	436	143	579	
420		4	405	103	508	384	114	498	362	127	489	340	141	481	316	157	473
		5	420	104	524	398	115	513	376	127	503	353	141	494	329	157	486
		6	435	104	539	413	115	528	390	128	518	367	141	508	342	157	499
	7	451	105	556	428	116	544	405	128	533	381	142	523	356	158	514	
	8	466	106	572	444	117	561	420	129	549	396	142	538	370	158	528	
	9	483	107	590	460	117	577	435	129	564	410	143	553	384	158	542	
	10	500	111	610	476	122	598	451	134	585	425	148	573	399	163	562	
	11	517	112	628	492	123	615	467	135	602	441	148	589	414	164	577	
	12	534	113	647	509	123	633	484	136	619	457	149	606	429	164	593	
	13	552	114	665	526	124	651	500	136	637	473	150	623	444	165	609	
	14	570	115	684	544	125	670	517	137	655	489	151	640	460	166	626	
	15	588	116	704	562	126	688	535	138	673	506	152	658	477	166	643	
	500	4	476	122	598	452	133	585	426	145	571	400	157	557	372	169	541
		5	494	124	618	469	135	604	443	146	589	416	158	574	388	171	559
		6	512	125	637	486	136	622	460	148	608	432	160	592	403	173	576
7		531	126	657	504	137	641	477	149	626	449	162	611	419	174	593	
8		549	127	676	523	139	662	495	151	646	466	163	629	436	176	612	
9		569	128	697	541	140	681	513	152	665	483	165	648	452	178	630	
10		588	133	721	560	146	706	531	158	689	501	171	672	469	185	654	
11		608	135	743	580	147	727	550	160	710	519	173	692	487	187	674	
12		629	136	764	600	148	748	569	161	731	538	175	713	505	189	694	
13		649	137	786	620	149	769	589	163	752	557	176	733	524	190	714	
14		671	138	809	640	151	791	609	164	773	576	178	754	542	192	735	
15		692	139	831	661	152	814	630	166	795	596	180	776	561	194	756	
600		4	565	147	712	537	164	701	508	184	692	478	206	684	446	233	679
		5	585	148	733	557	164	721	527	184	711	496	206	702	464	232	696
		6	605	148	753	576	165	741	546	184	730	515	206	721	482	232	714
	7	626	149	775	596	166	762	566	184	750	534	206	740	500	231	731	
	8	646	150	796	617	166	783	586	185	771	553	206	759	519	231	750	
	9	667	151	818	637	167	804	606	185	791	573	206	779	538	231	769	
	10	689	156	845	658	173	831	626	192	818	593	213	806	557	238	795	
	11	710	157	868	679	174	853	647	192	839	613	213	826	577	238	815	
	12	733	158	891	701	175	876	668	193	861	634	214	848	597	238	835	
	13	755	159	915	723	176	899	689	194	883	654	215	869	618	238	856	
	14	778	160	939	746	177	922	711	195	906	676	215	891	638	239	877	
	15	802	162	963	768	178	946	734	196	929	697	216	913	659	239	898	
	650	4	623	161	784	592	179	771	560	200	760	527	223	750	492	250	742
		5	645	162	807	614	180	794	581	200	781	547	223	770	511	250	761
		6	667	163	830	635	180	815	602	201	803	567	224	791	531	250	781
7		689	164	853	657	181	838	624	201	825	588	224	812	551	250	801	
8		712	165	877	679	182	861	646	202	848	610	224	834	572	250	822	
9		735	166	901	702	183	885	668	203	871	631	225	856	593	250	843	
10		759	172	931	725	190	915	690	210	900	653	232	885	614	258	872	
11		783	173	956	749	191	939	713	211	924	676	233	908	636	258	894	
12		807	174	981	772	192	964	736	212	948	698	234	932	658	259	917	
13		832	176	1007	796	193	990	760	213	973	721	235	956	681	259	940	
14		857	177	1034	821	194	1015	784	214	998	745	236	980	703	260	963	
15		882	178	1060	846	196	1042	808	215	1023	768	237	1005	727	261	987	

NOTES

Cc (cooling capacity) - Pi (unit power input) - Hr (heat rejection) - ELWT (evaporator leaving water temperature - Δt 5°C)
 Data are referred to 0.0176 m² °C/kW evaporator fouling factor

SRC_1-2-3_Rev.00_1

5 Capacity tables

5 - 1 Cooling Capacity Tables

EWLD750~C10I-SS

Size	ELWT (°C)	Saturated Discharge Temperature (°C)															
		40			45			50			55			60			
		Cc (kW)	Pi (kW)	Hr (kW)	Cc (kW)	Pi (kW)	Hr (kW)	Cc (kW)	Pi (kW)	Hr (kW)	Cc (kW)	Pi (kW)	Hr (kW)	Cc (kW)	Pi (kW)	Hr (kW)	
750	4	692	176	868	658	195	853	622	216	838	585	240	825	546	268	814	
	5	716	177	893	681	196	877	645	217	862	607	241	848	567	268	835	
	6	741	178	919	706	197	903	669	218	887	630	241	871	589	268	857	
	7	766	179	945	730	198	928	693	219	912	653	242	895	612	269	881	
	8	792	181	973	755	199	954	717	220	937	677	243	920	635	269	904	
	9	818	182	1000	781	200	981	742	221	963	701	244	945	658	270	928	
	10	844	189	1033	807	208	1015	768	229	997	728	252	980	686	279	964	
	11	871	190	1061	833	209	1042	794	230	1023	752	253	1006	709	280	989	
	12	897	192	1089	859	210	1069	819	231	1050	777	254	1032	733	280	1014	
	13	925	193	1118	886	212	1098	845	232	1078	803	255	1058	758	281	1039	
	14	953	195	1147	913	213	1126	872	234	1105	828	257	1085	783	282	1065	
	15	981	196	1177	941	215	1156	899	235	1134	855	258	1113	808	284	1092	
	800	4	746	191	937	710	211	921	671	235	906	631	261	892	589	291	880
		5	773	192	965	735	212	947	696	235	931	655	262	917	612	291	903
		6	799	193	992	761	213	974	721	236	957	680	262	942	636	291	927
7		826	194	1020	788	215	1003	747	237	984	705	263	968	660	292	952	
8		854	196	1050	815	216	1031	774	238	1012	730	264	994	685	292	977	
9		882	197	1079	842	217	1059	800	239	1039	756	265	1021	710	293	1003	
10		911	205	1115	870	225	1095	828	248	1075	783	273	1056	736	302	1038	
11		940	206	1146	899	226	1125	855	249	1104	810	275	1084	762	303	1065	
12		969	208	1177	927	228	1155	883	251	1134	837	276	1113	789	304	1093	
13		1000	209	1209	957	230	1186	912	252	1164	865	277	1142	816	305	1121	
14		1030	211	1241	987	231	1218	941	254	1195	894	279	1172	844	306	1150	
15		1062	213	1274	1017	233	1250	971	255	1226	922	280	1202	872	308	1179	
850		4	806	206	1012	767	228	995	726	253	979	683	282	965	637	314	951
		5	834	207	1041	794	229	1023	752	254	1006	708	282	990	662	314	976
		6	862	208	1070	822	230	1052	779	255	1034	735	283	1018	688	315	1003
	7	891	210	1101	850	232	1082	807	256	1063	761	284	1045	714	315	1029	
	8	920	211	1131	879	233	1112	835	257	1092	789	285	1074	740	316	1056	
	9	949	213	1162	908	234	1142	863	258	1121	817	286	1103	767	316	1083	
	10	966	220	1186	923	242	1165	879	267	1146	832	295	1127	783	326	1109	
	11	997	222	1218	953	244	1197	908	268	1176	860	296	1156	811	327	1138	
	12	1028	223	1251	984	245	1229	937	270	1207	889	297	1186	839	328	1166	
	13	1059	225	1284	1014	247	1261	967	271	1239	918	298	1217	867	329	1196	
	14	1092	227	1318	1046	249	1294	998	273	1271	948	300	1248	896	330	1226	
	15	1124	228	1353	1078	250	1328	1029	274	1304	978	301	1279	925	331	1256	
	900	4	871	225	1096	829	247	1076	785	271	1056	738	297	1035	689	325	1014
		5	901	226	1127	858	248	1106	813	272	1085	766	299	1065	716	327	1043
		6	932	228	1160	888	250	1138	842	274	1116	794	300	1094	744	329	1073
7		963	230	1193	919	252	1171	872	276	1148	823	302	1125	772	331	1103	
8		995	232	1227	950	254	1204	902	278	1180	853	304	1157	801	333	1134	
9		1027	234	1261	981	256	1237	933	280	1213	883	306	1189	830	335	1165	
10		1029	241	1270	985	264	1248	938	289	1226	888	316	1204	836	345	1181	
11		1061	243	1304	1016	266	1282	968	291	1259	918	318	1236	865	347	1213	
12		1094	244	1338	1047	268	1315	999	293	1292	948	320	1268	895	349	1244	
13		1127	246	1373	1080	270	1349	1031	295	1326	979	322	1301	925	352	1276	
14		1160	248	1408	1112	272	1384	1063	297	1359	1010	324	1335	955	354	1309	
15		1194	250	1444	1146	274	1419	1095	299	1394	1042	326	1368	986	356	1342	
950		4	915	242	1157	871	264	1135	824	287	1111	775	311	1086	723	335	1058
		5	947	244	1191	902	267	1169	854	290	1144	804	314	1118	752	339	1091
		6	980	247	1227	933	269	1202	885	292	1177	834	317	1151	781	342	1123
	7	1013	249	1262	966	272	1238	916	295	1211	865	320	1185	810	346	1156	
	8	1046	251	1297	998	274	1272	948	298	1246	896	323	1219	841	349	1190	
	9	1080	253	1333	1032	276	1308	981	301	1282	927	326	1253	871	352	1223	
	10	1084	261	1345	1037	285	1322	988	310	1298	936	337	1273	882	364	1246	
	11	1118	263	1381	1070	287	1357	1020	313	1333	967	339	1307	912	367	1279	
	12	1152	265	1417	1103	290	1393	1052	316	1368	999	342	1341	943	370	1313	
	13	1187	267	1454	1137	292	1430	1086	318	1404	1031	345	1377	974	374	1348	
	14	1223	269	1492	1172	295	1467	1119	321	1440	1064	348	1412	1006	377	1383	
	15	1259	272	1530	1207	297	1504	1154	323	1477	1098	351	1449	1039	380	1419	
	C10	4	953	248	1201	908	276	1184	860	307	1167	811	343	1154	758	384	1142
		5	984	250	1234	939	277	1216	891	308	1199	841	344	1185	787	384	1171
		6	1017	251	1268	971	278	1249	922	309	1231	871	344	1215	817	384	1201
7		1050	252	1302	1003	279	1282	954	310	1264	902	345	1247	847	384	1231	
8		1083	254	1337	1035	281	1316	986	311	1297	933	345	1278	877	384	1261	
9		1117	256	1373	1069	282	1351	1018	312	1330	965	346	1311	909	385	1294	
10		1151	265	1416	1102	292	1394	1051	323	1374	997	358	1354	940	397	1337	
11		1186	267	1453	1136	294	1430	1084	324	1409	1029	359	1388	972	397	1369	
12		1222	269	1490	1171	296	1467	1118	326	1444	1063	360	1422	1004	398	1402	
13		1258	270	1528	1206	297	1504	1153	327	1480	1096	361	1457	1037	399	1436	
14		1294	272	1567	1242	299	1541	1188	329	1517	1130	363	1493	1070	400	1471	
15		1332	274	1606	1279	301	1580	1223	331	1554	1165	364	1529	1104	401	1505	

NOTES

Cc (cooling capacity) - Pi (unit power input) - Hr (heat rejection) - ELWT (evaporator leaving water temperature - Δt 5°C)
 Data are referred to 0.0176 m² °C/kW evaporator fouling factor

SRC_1-2-3_Rev.00_2

5 Capacity tables

5 - 1 Cooling Capacity Tables

EWLDC11~C14I-SS

Size	ELWT (°C)	Saturated Discharge Temperature (°C)															
		40			45			50			55			60			
		Cc (kW)	Pi (kW)	Hr (kW)	Cc (kW)	Pi (kW)	Hr (kW)	Cc (kW)	Pi (kW)	Hr (kW)	Cc (kW)	Pi (kW)	Hr (kW)	Cc (kW)	Pi (kW)	Hr (kW)	
C11	4	1023	263	1286	974	291	1265	922	324	1246	868	360	1228	811	402	1213	
	5	1058	265	1323	1008	293	1301	955	325	1280	900	361	1261	842	402	1244	
	6	1093	266	1359	1043	294	1337	989	326	1315	933	362	1295	875	403	1278	
	7	1129	268	1397	1078	296	1374	1024	327	1351	967	363	1330	907	403	1310	
	8	1165	270	1435	1114	298	1412	1059	329	1388	1001	364	1365	940	404	1344	
	9	1201	272	1473	1150	299	1449	1095	330	1425	1036	365	1401	974	404	1378	
	10	1237	282	1519	1186	310	1496	1131	342	1472	1072	377	1449	1009	417	1426	
	11	1274	284	1558	1222	312	1534	1167	344	1510	1107	379	1486	1044	419	1462	
	12	1312	286	1597	1258	314	1572	1203	345	1548	1144	380	1524	1080	420	1499	
	13	1350	288	1637	1296	316	1611	1239	347	1586	1179	382	1561	1115	421	1537	
	14	1388	290	1678	1333	318	1651	1276	349	1625	1215	384	1599	1152	423	1575	
	15	1427	292	1719	1372	320	1692	1313	351	1664	1252	386	1638	1188	424	1612	
	C12	4	1069	277	1346	1018	308	1326	965	342	1307	909	381	1290	849	425	1274
		5	1104	279	1383	1053	309	1362	999	343	1342	942	382	1324	882	425	1307
		6	1140	281	1421	1089	311	1400	1034	344	1378	976	382	1358	916	426	1342
7		1177	283	1460	1125	312	1437	1070	346	1416	1011	383	1394	949	426	1375	
8		1214	284	1498	1161	314	1475	1105	347	1452	1047	384	1431	984	427	1411	
9		1251	286	1537	1198	316	1514	1142	349	1491	1082	386	1468	1019	427	1446	
10		1288	297	1585	1235	327	1561	1178	361	1539	1118	398	1516	1054	441	1495	
11		1326	299	1625	1272	329	1601	1215	362	1577	1154	400	1554	1090	442	1532	
12		1365	301	1665	1310	331	1640	1252	364	1616	1192	401	1593	1126	443	1570	
13		1404	303	1707	1348	333	1681	1290	366	1656	1228	403	1631	1163	445	1607	
14		1444	305	1749	1387	335	1722	1328	368	1696	1265	405	1670	1200	446	1646	
15		1484	307	1791	1427	337	1763	1366	370	1736	1303	407	1710	1237	448	1684	
C13		4	1128	293	1421	1074	324	1398	1017	361	1378	957	402	1359	894	448	1342
		5	1167	294	1461	1111	326	1437	1054	362	1416	993	402	1395	929	448	1377
		6	1205	296	1501	1150	328	1478	1091	363	1454	1029	403	1432	965	449	1414
	7	1245	298	1543	1189	329	1518	1129	364	1493	1067	404	1471	1001	449	1450	
	8	1285	300	1585	1228	331	1559	1168	366	1534	1104	405	1509	1037	450	1487	
	9	1325	302	1627	1267	333	1600	1207	368	1575	1143	407	1550	1075	451	1526	
	10	1367	313	1680	1308	345	1653	1246	380	1626	1181	420	1602	1113	465	1578	
	11	1409	315	1724	1349	347	1696	1286	382	1668	1221	422	1642	1151	466	1617	
	12	1451	318	1769	1391	349	1740	1327	384	1711	1260	423	1684	1190	468	1658	
	13	1495	320	1815	1433	351	1784	1368	386	1755	1301	425	1726	1229	469	1698	
	14	1539	322	1861	1476	354	1830	1410	388	1799	1342	427	1769	1269	471	1740	
	15	1583	325	1908	1520	356	1876	1453	391	1844	1383	429	1812	1310	472	1782	
	C14	4	1201	308	1509	1143	342	1485	1082	379	1461	1018	422	1440	950	471	1421
		5	1243	310	1553	1184	343	1527	1121	381	1502	1056	423	1479	988	471	1459
		6	1285	312	1597	1225	345	1570	1162	382	1544	1096	424	1520	1026	472	1498
7		1328	314	1642	1267	347	1614	1203	384	1587	1135	425	1560	1064	472	1536	
8		1371	316	1687	1309	349	1658	1244	385	1629	1176	427	1603	1104	473	1577	
9		1416	319	1735	1353	351	1704	1287	387	1674	1217	428	1645	1144	474	1618	
10		1461	331	1792	1397	364	1760	1330	401	1730	1259	442	1702	1185	489	1674	
11		1507	333	1840	1441	366	1807	1373	403	1776	1302	444	1746	1226	491	1717	
12		1554	335	1889	1487	368	1856	1418	405	1823	1345	446	1791	1269	492	1761	
13		1601	338	1939	1534	371	1904	1463	407	1870	1389	448	1837	1311	494	1805	
14		1650	341	1990	1581	373	1954	1509	410	1919	1434	450	1884	1355	496	1850	
15		1699	343	2042	1629	376	2005	1556	412	1968	1479	452	1932	1399	497	1897	

NOTES

Cc (cooling capacity) - Pi (unit power input) - Hr (heat rejection) - ELWT (evaporator leaving water temperature - Δt 5°C)
 Data are referred to 0.0176 m² °C/kW evaporator fouling factor

5 Capacity tables

5 - 1 Cooling Capacity Tables

EWLDC15~C17I-SS

Size	ELWT (°C)	Saturated Discharge Temperature (°C)															
		40			45			50			55			60			
		Cc (kW)	Pi (kW)	Hr (kW)	Cc (kW)	Pi (kW)	Hr (kW)	Cc (kW)	Pi (kW)	Hr (kW)	Cc (kW)	Pi (kW)	Hr (kW)	Cc (kW)	Pi (kW)	Hr (kW)	
C15	4	1251	326	1577	1191	359	1550	1128	396	1524	1062	436	1498	992	481	1473	
	5	1294	328	1622	1233	362	1595	1169	398	1567	1101	438	1539	1031	483	1514	
	6	1338	331	1669	1275	364	1639	1210	400	1610	1142	441	1583	1070	485	1555	
	7	1382	333	1715	1319	366	1685	1253	403	1656	1183	443	1626	1110	487	1597	
	8	1427	336	1763	1363	369	1732	1295	405	1700	1225	445	1670	1151	489	1640	
	9	1472	338	1810	1407	371	1778	1339	408	1747	1267	448	1715	1192	491	1683	
	10	1519	351	1870	1453	385	1838	1383	423	1806	1311	464	1774	1234	509	1743	
	11	1566	354	1920	1499	388	1887	1429	425	1854	1355	466	1821	1277	511	1788	
	12	1615	356	1971	1546	391	1937	1474	428	1902	1399	469	1868	1320	514	1834	
	13	1664	359	2023	1594	394	1988	1521	431	1952	1445	472	1916	1365	516	1881	
	14	1714	362	2076	1643	396	2039	1569	434	2002	1491	475	1965	1410	519	1929	
	15	1765	365	2129	1692	399	2092	1617	437	2054	1538	477	2015	1455	522	1977	
	C16	4	1301	344	1645	1239	377	1616	1174	412	1586	1106	451	1557	1034	492	1526
		5	1345	347	1692	1282	380	1662	1216	415	1631	1147	454	1601	1074	495	1569
		6	1390	349	1739	1326	383	1709	1259	419	1678	1189	457	1646	1114	498	1612
7		1436	352	1788	1371	386	1757	1302	422	1724	1231	460	1691	1156	502	1658	
8		1482	355	1837	1416	389	1805	1347	425	1772	1274	464	1738	1198	505	1703	
9		1529	358	1887	1462	392	1854	1392	428	1820	1318	467	1785	1240	509	1749	
10		1577	372	1949	1509	407	1915	1437	444	1882	1362	485	1847	1283	528	1811	
11		1626	374	2000	1556	410	1966	1484	448	1931	1407	488	1896	1327	531	1859	
12		1676	377	2053	1605	413	2018	1531	451	1982	1454	492	1945	1372	535	1907	
13		1726	380	2107	1654	416	2071	1579	454	2034	1500	495	1996	1418	539	1957	
14		1778	383	2161	1705	419	2124	1628	458	2086	1548	499	2047	1464	543	2007	
15		1830	386	2216	1756	423	2178	1678	461	2139	1597	502	2099	1511	547	2058	
C17		4	1351	362	1713	1287	394	1681	1220	429	1649	1150	465	1615	1076	502	1578
		5	1396	365	1761	1332	398	1730	1264	433	1697	1192	469	1661	1117	507	1624
		6	1442	368	1810	1377	402	1779	1308	437	1745	1235	474	1709	1159	512	1671
	7	1489	371	1860	1422	405	1827	1352	441	1793	1279	478	1757	1201	517	1718	
	8	1537	374	1911	1469	409	1878	1398	445	1843	1323	482	1805	1244	522	1766	
	9	1586	377	1963	1516	412	1928	1444	449	1893	1368	487	1855	1288	526	1814	
	10	1635	392	2027	1565	428	1993	1491	466	1957	1414	506	1919	1333	547	1880	
	11	1686	395	2081	1614	432	2046	1539	470	2009	1460	510	1970	1378	552	1930	
	12	1737	398	2135	1664	435	2099	1588	474	2062	1508	514	2022	1424	557	1981	
	13	1789	401	2190	1715	439	2154	1637	478	2115	1556	519	2075	1471	562	2032	
	14	1842	405	2246	1767	442	2209	1688	482	2170	1605	523	2128	1519	566	2085	
	15	1896	408	2303	1819	446	2265	1739	486	2225	1655	527	2183	1567	571	2138	

NOTES

Cc (cooling capacity) - Pi (unit power input) - Hr (heat rejection) - ELWT (evaporator leaving water temperature - Δt 5°C)
 Data are referred to 0.0176 m² °C/kW evaporator fouling factor

6 Dimensional drawings

6 - 1 Dimensional Drawings

EWLD320-500I-SS

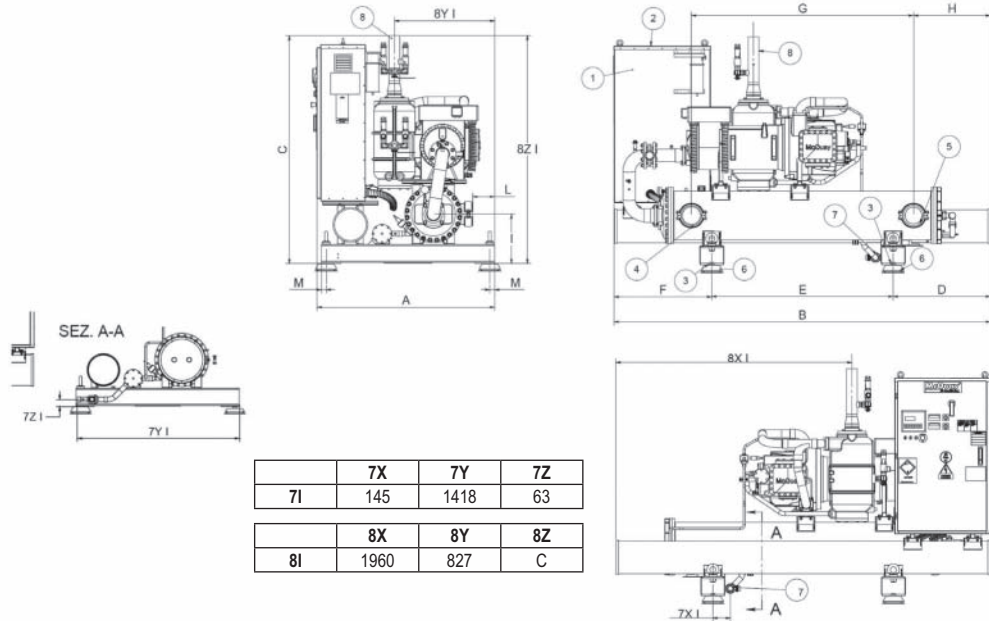

Dimensions											
EWLD-I-	A	B	C	D	E	F	G	H	I	L	M
320-500I-SS	1468	3114	1899	805	1500	809	1837	637	412	182	40

LEGEND

- 1 - Electrical Panel
- 2 - Power connections slot 150x200
- 3 - Four (4) holes Ø21 for isolator mounting
- 4 - Evaporator water inlet (Victaulic connection) [168.3mm]
- 5 - Evaporator water outlet (Victaulic connection) [168.3mm]
- 6 - Isolators (optional)
- 7 - Liquid line inlet connection [Ø42]
- 8 - Discharge line connection [Ø88.9]

DMN_1-2-3_Rev.00_1

EWLD600-950I-SS

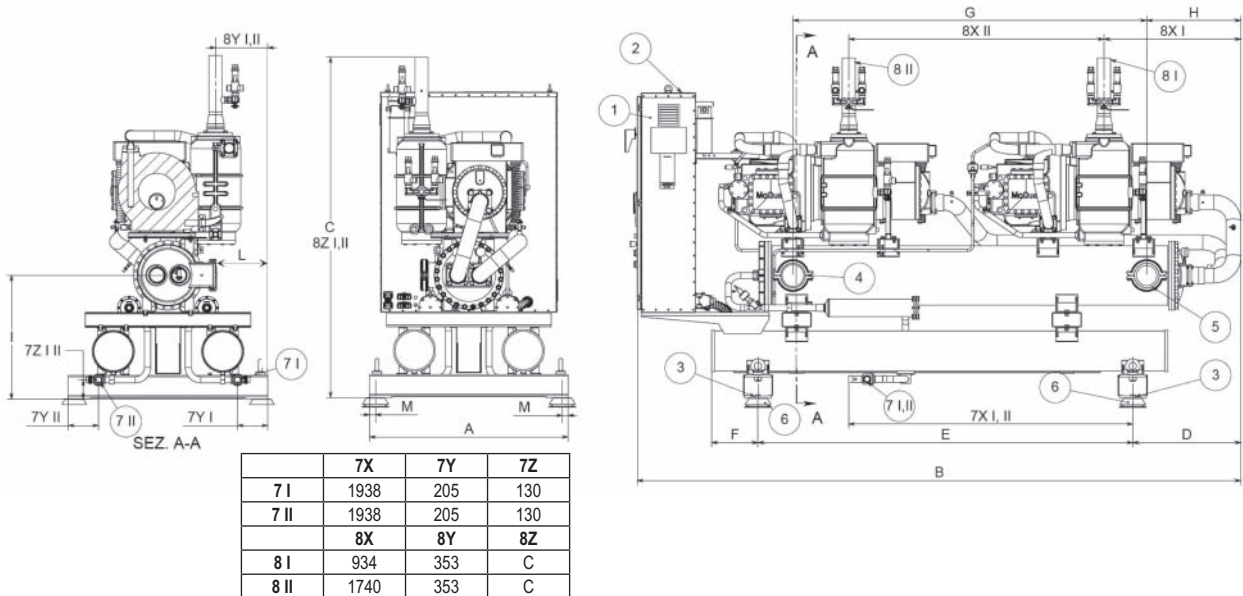

Dimensions											
EWLD-I-	A	B	C	D	E	F	G	H	I	L	M
600-950I-SS	1350	4116	2323	7379	2555	1068	2412	643	838	346	40

LEGEND

- 1 - Electrical Panel
- 2 - Power connections slot 150x200
- 3 - Four (4) holes Ø21 for isolator mounting
- 4 - Evaporator water inlet (Victaulic connection) [168.3mm]
- 5 - Evaporator water outlet (Victaulic connection) [168.3mm]
- 6 - Isolators (optional)
- 7 - Liquid line inlet connection [Ø42]
- 8 - Discharge line connection [Ø88.9]

DMN_1-2-3_Rev.00_2

6 Dimensional drawings

6 - 1 Dimensional Drawings

EWLDC10-C17I-SS

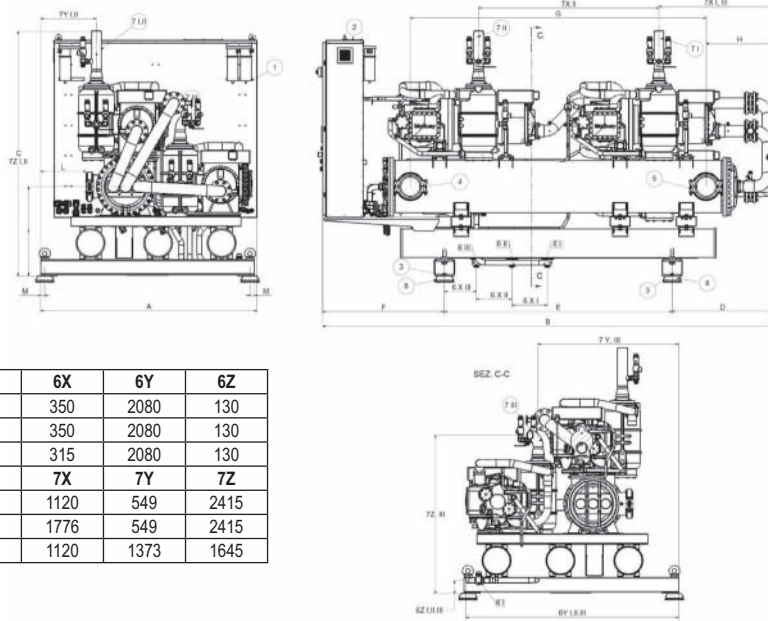

	6X	6Y	6Z
6 I	350	2080	130
6 II	350	2080	130
6 III	315	2080	130
	7X	7Y	7Z
7 I	1120	549	2415
7 II	1776	549	2415
7 III	1120	1373	1645

Dimensions											
EWLD~I-	A	B	C	D	E	F	G	H	I	L	M
C10-C17I-SS	2128	4427	2415	1041	2200	1198	2910	656	880	446	40

LEGEND

- 1 - Electrical Panel
- 2 - Power connections slot 150x350
- 3 - Four (4) holes Ø21 for isolator mounting
- 4 - Evaporator water inlet (Victaulic connection) [219.1mm]
- 5 - Evaporator water outlet (Victaulic connection) [219.1mm]
- 6 - Liquid line inlet connection [Ø42]
- 7 - Discharge line connection [Ø88.9]
- 8 - Isolators (optional)

DMN_1-2-3_Rev.00_3

7 Sound data

7 - 1 Sound Level Data

Sound level

EWLD-I-SS

Unit size	Sound pressure level at 1 m from the unit in semispheric free field (rif. 2×10^{-5} Pa)								Power	
	63 Hz	125 Hz	250 Hz	500 Hz	1000 Hz	2000 Hz	4000 Hz	8000 Hz	dB(A)	dB(A)
320	53.6	56.2	71.1	74.5	69.7	65.6	63.9	59.5	75.2	93.7
400	54.6	57.2	72.1	75.5	70.7	66.6	64.9	60.5	76.2	96.6
420	56.6	59.2	74.1	77.5	72.7	68.6	66.9	62.5	78.2	96.7
500	56.6	59.2	74.1	77.5	72.7	68.6	66.9	62.5	78.2	96.7
600	56.2	58.8	73.7	77.1	72.3	68.2	66.5	62.1	77.8	96.9
650	56.6	59.2	74.1	77.5	72.7	68.6	66.9	62.5	78.2	97.3
750	57.1	59.7	74.6	78.0	73.2	69.1	67.4	63.0	78.7	97.8
800	58.2	60.8	75.7	79.1	74.3	70.2	68.5	64.1	79.8	98.9
850	59.1	61.7	76.6	80.0	75.2	71.1	69.4	65.0	80.7	99.8
900	59.1	61.7	76.6	80.0	75.2	71.1	69.4	65.0	80.7	99.8
950	59.1	61.7	76.6	80.0	75.2	71.1	69.4	65.0	80.7	99.8
C10	58.5	61.1	76.0	79.4	74.6	70.5	68.8	64.4	80.1	100.1
C11	58.8	61.4	76.3	79.7	74.9	70.8	69.1	64.7	80.4	100.4
C12	59.2	61.8	76.7	80.1	75.3	71.2	69.5	65.1	80.8	100.8
C13	59.6	62.2	77.1	80.5	75.7	71.6	69.9	65.5	81.2	101.2
C14	61.4	64.0	78.9	82.3	77.5	73.4	71.7	67.3	83.0	103.0
C15	61.4	64.0	78.9	82.3	77.5	73.4	71.7	67.3	83.0	103.0
C16	61.4	64.0	78.9	82.3	77.5	73.4	71.7	67.3	83.0	103.0
C17	61.4	64.0	78.9	82.3	77.5	73.4	71.7	67.3	83.0	103.0

NOTE

The values are according to ISO 3744 and are referred to: evaporator 12/7° C, saturated discharge temperature 45° C, full load operation

7 Sound data

7 - 1 Sound Level Data

Sound pressure levels correction for different distances

EWLD-I-SS

Unit size	Distance					
	1m	5m	10m	15m	20m	25m
320	0.0	-7.9	-12.7	-15.8	-18.1	-19.8
400	0.0	-7.9	-12.7	-15.8	-18.1	-19.8
420	0.0	-7.9	-12.7	-15.8	-18.1	-19.8
500	0.0	-7.9	-12.7	-15.8	-18.1	-19.8
600	0.0	-7.9	-12.7	-15.8	-18.1	-19.8
650	0.0	-7.5	-12.2	-15.3	-17.5	-19.3
750	0.0	-7.9	-12.7	-15.8	-18.1	-19.8
800	0.0	-7.5	-12.2	-15.3	-17.5	-19.3
850	0.0	-7.5	-12.2	-15.3	-17.5	-19.3
900	0.0	-7.9	-12.7	-15.8	-18.1	-19.8
950	0.0	-7.5	-12.2	-15.3	-17.5	-19.3
C10	0.0	-7.5	-12.2	-15.3	-17.5	-19.3
C11	0.0	-7.5	-12.2	-15.3	-17.5	-19.3
C12	0.0	-7.5	-12.2	-15.3	-17.5	-19.3
C13	0.0	-7.5	-12.2	-15.3	-17.5	-19.3
C14	0.0	-7.5	-12.2	-15.3	-17.5	-19.3
C15	0.0	-7.5	-12.2	-15.3	-17.5	-19.3
C16	0.0	-7.5	-12.2	-15.3	-17.5	-19.3
C17	0.0	-7.5	-12.2	-15.3	-17.5	-19.3

8 Installation

8 - 1 Installation Method

Installation notes

Warning

Installation and maintenance are to be performed only by qualified personnel who are familiar with local codes and regulations, and who are experienced with this type of equipment. Must be avoided the unit installation in places that could be considered dangerous for all the maintenance operations.

Handling

The chiller is mounted on heavy wooden skids to protect the unit from accidental damage and to permit easy handling and moving. It is recommended that all moving and handling be performed with the skids under the unit when possible and that the skids not be removed until the unit is in the final location.

If the unit must be hoisted, it is necessary to lift the unit by attaching cables or chains at the lifting holes in the evaporator tube sheets. Spreader bars must be used to protect the control cabinet and the other areas of the chiller.

Location

A leveled and sufficiently strong floor is required. If necessary, additional structural members should be provided to transfer the weight of the unit to the nearest beams.

Rubber-in-shear isolators can be furnished and field placed under each corner of the package. A rubber anti-skid pad should be used under isolators if hold-down bolts are not used. Vibration isolator in all water piping connected to the chiller is recommended to avoid straining the piping and transmitting vibration and noise.

Minimum space requirements

Every side of the machine must be accessible for all post-installation maintenance activities. The minimum space required is shown on the following drawing:

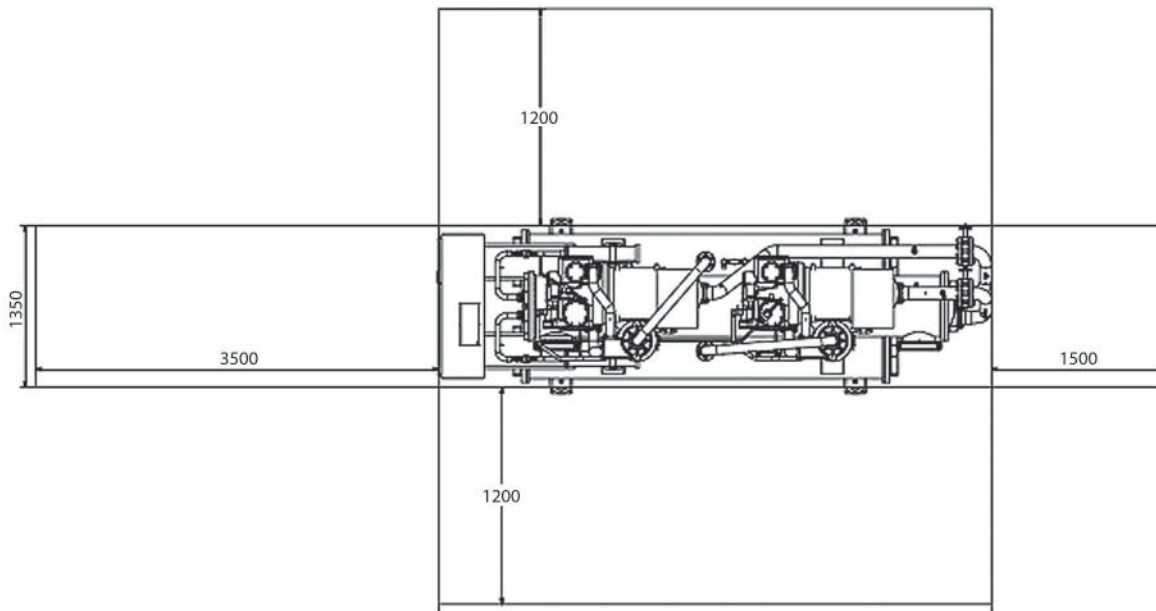

Minimum clearance requirements for machine maintenance

9 Operation range

9 - 1 Operation Range

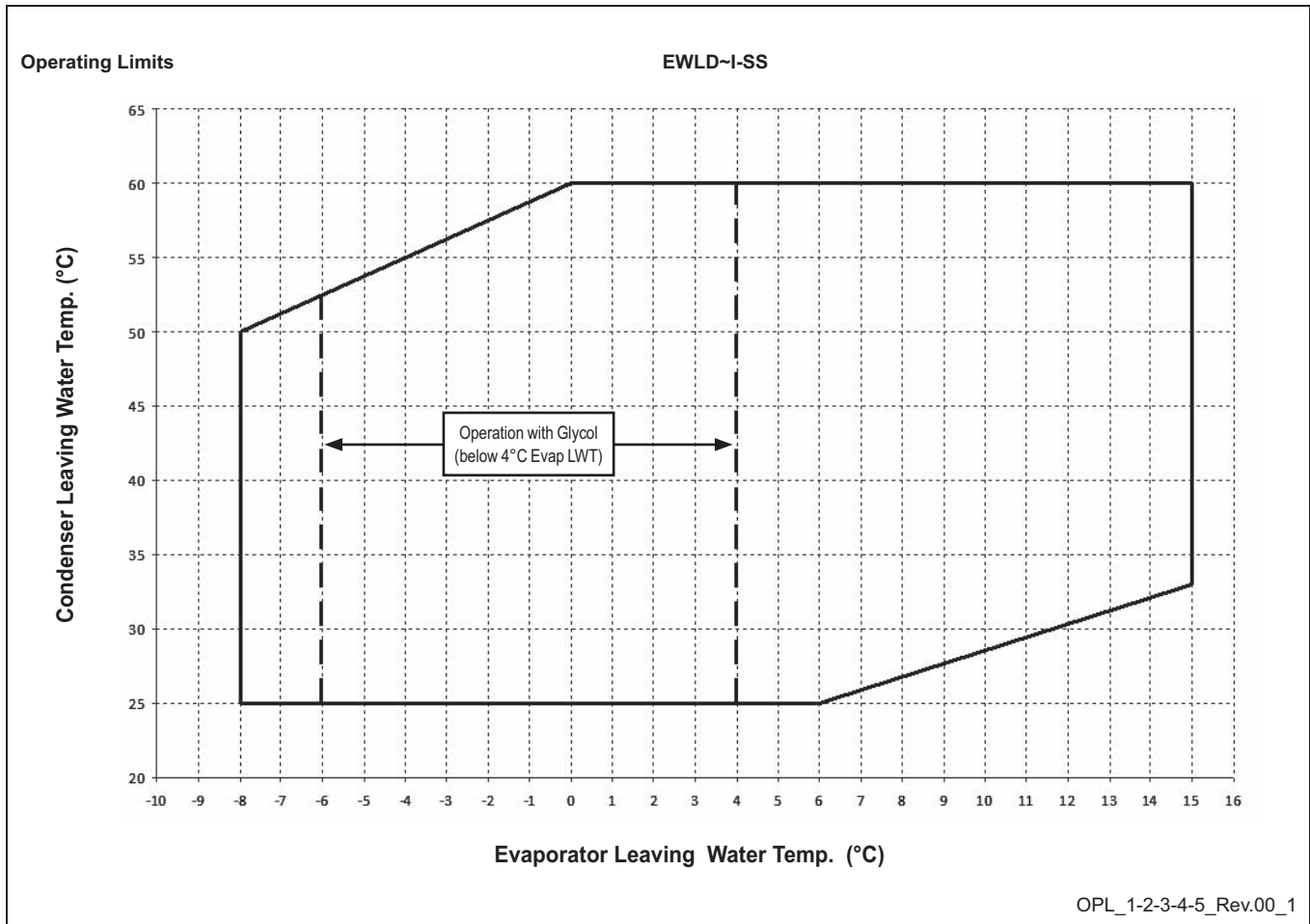

9 Operation range

9 - 1 Operation Range

Table 1 - Evaporator minimum and maximum water

Max evaporator water Δt	°C	8
Min evaporator water Δt	°C	4

Table 2 - Evaporator fouling factors

Fouling factors $m^2 \text{ } ^\circ\text{C} / \text{kW}$	Cooling capacity correction factor	Power input correction factor	EER correction factor
0.0176	1.000	1.000	1.000
0.0440	0.978	0.986	0.992
0.0880	0.957	0.974	0.983
0.1320	0.938	0.962	0.975

Table 3.1 - Minimum glycol percentage for low water temperature

Evaporator Leaving Water Temperature (°C)	2	0	-2	-4	-6	-8
Ethylene glycol (%)	10	20	20	20	30	30
Propylene glycol (%)	10	20	20	30	30	30

Note: Minimum glycol percentage to be used with evaporator leaving water temperature below 4°C to prevent freezing of water circuit.

Table 3.2 - Minimum glycol percentage for low air temperature

Air Ambient Temperature (°C) (2)	-3	-8	-15	-23	-35
Ethylene glycol (%) (1)	10%	20%	30%	40%	50%
Air Ambient Temperature (°C) (2)	-3	-7	-12	-20	-32
Propylene glycol (%) (1)	10%	20%	30%	40%	50%

Note (1): Minimum glycol percentage to prevent freezing of water circuit at indicated air ambient temperature.

Note (2): Air ambient temperature do exceed the operating limits of the unit, as protection of water circuit may be needed in winter season at non-working conditions

Table 4 - Correction factors for low evaporator leaving water temperature

Evaporator Leaving Water Temperature (°C)	2	0	-2	-4	-6	-8
Cooling Capacity	0.842	0.785	0.725	0.670	0.613	0.562
Compressor Power Input	0.950	0.940	0.920	0.890	0.870	0.840

Note: Correction factors have to be applied at working conditions: evaporator leaving water temperature 7°C

Table 5 - Correction factors for water and glycol mixture

	Ethylene Glycol (%)	10%	20%	30%	40%	50%
Ethylene Glycol	Cooling Capacity	0.991	0.982	0.972	0.961	0.946
	Compressor Power Input	0.996	0.992	0.986	0.976	0.966
	Flow Rate (Δt)	1.013	1.04	1.074	1.121	1.178
	Evaporator Pressure Drop	1.070	1.129	1.181	1.263	1.308
Propylene Glycol	Cooling Capacity	0.985	0.964	0.932	0.889	0.846
	Compressor Power Input	0.993	0.983	0.969	0.948	0.929
	Flow Rate (Δt)	1.017	1.032	1.056	1.092	1.139
	Evaporator Pressure Drop	1.120	1.272	1.496	1.792	2.128

9 Operation range

9 - 1 Operation Range

How to use the Correction factors proposed in the previous tables

A) Mixture Water and Glycol --- Evaporator leaving water temperature > 4°C

- depending from the type and percentage (%) of glycol filled in the circuit (see table 3.2 and 5)
- multiply the Cooling Capacity, the Compressor Power Input by the Correction factor of Table 5
- starting from this new value of Cooling Capacity, calculate the Flow Rate (l/s) and the Evaporator Pressure Drop (kPa)
- now multiply the new Flow Rate and the new Evaporator Pressure Drop by the Correction Factors of Table 5

Example

Unit Size: **EWLD320I-SS**

Mixture: Water
 Working condition: ELWT 12/7°C – Saturated Discharge Temperature 45°C
 - Cooling capacity: 328kW
 - Power input: 83.8kW
 - Flow rate (Δt 5°C): 15.67 l/s
 - Evaporator pressure drop: 36kPa

Mixture: Water + Ethylene Glycol 30% (for a winter air temperature up to -15°C)
 Working condition: ELWT 12/7°C – Saturated Discharge Temperature 45°C
 - Cooling capacity: $328 \times 0.972 = 319 \text{ kW}$
 - Power input: $83.8 \times 0.986 = 82.6 \text{ kW}$
 - Flow rate (Δt 5°C): $15.24 \text{ (referred to 328 kW)} \times 1.074 = 16.36 \text{ l/s}$
 - Evaporator pressure drop: $39 \text{ (referred to 16.36l/s)} \times 1.181 = 46\text{kPa}$

B) Mixture Water and Glycol --- Evaporator leaving water temperature < 4°C

- depending from the type and percentage (%) of glycol filled in the circuit (see table 3.1 and 3.2 and table 4)
- depending from the evaporator leaving water temperature (see table 4)
- multiply the Cooling Capacity, the Compressor Power Input by the Correction factor of Table 4 and Table 5
- starting from this new value of Cooling Capacity, calculate the Flow Rate (l/s) and the Evaporator Pressure Drop (kPa)
- now multiply the new Flow Rate and the new Evaporator Pressure Drop by the Correction Factors of Table 5

Example

Unit Size: **EWLD320I-SS**

Mixture: Water
 Standard working condition: ELWT 12/7°C – Saturated Discharge Temperature 40°C
 - Cooling capacity: 345kW
 - Power input: 75.9 kW
 - Flow rate (Δt 5°C): 16.48 l/s
 - Evaporator pressure drop: 39kPa

Mixture: Water + Glycol 30% (for a low evaporator leaving temperature of -1/-6°C)
 Working condition: ELWT -1/-6°C – Saturated Discharge Temperature 40°C
 - Cooling capacity: $345 \times 0.613 \times 0.972 = 206 \text{ kW}$
 - Power input: $75.9 \times 0.870 \times 0.986 = 65.11 \text{ kW}$
 - Flow rate (Δt 5°C): $9.84 \text{ l/s (referred to 206 kW)} \times 1.074 = 10.57 \text{ l/s}$
 - Evaporator pressure drop: $18 \text{ kPa (referred to 10.57 l/s)} \times 1.181 = 21 \text{ kPa}$

9 Operation range

9 - 1 Operation Range

Water charge, flow and quality

Items ⁽¹⁾⁽⁵⁾		Cooling Water			Cooled Water		Heated water ⁽²⁾				Tendency if out of criteria		
		Circulating System		Once Flow			Low temperature		High temperature				
		Circulating water	Supply water ⁽⁴⁾	Flowing water	Circulating water [Below 20°C]	Supply water ⁽⁴⁾	Circulating water [20°C ~ 60°C]	Supply water ⁽⁴⁾	Circulating water [60°C ~ 80°C]	Supply water ⁽⁴⁾			
Items to be controlled:	pH	at 25°C	6.5 ~ 8.2	6.0 ~ 8.0	6.0 ~ 8.0	6.0 ~ 8.0	6.0 ~ 8.0	7.0 ~ 8.0	7.0 ~ 8.0	7.0 ~ 8.0	7.0 ~ 8.0	Corrosion + Scale	
	Electrical conductivity	[mS/m] at 25°C	Below 80	Below 30	Below 40	Below 40	Below 30	Below 30	Below 30	Below 30	Below 30	Below 30	Corrosion + Scale
		[μS/cm] at 25°C	(Below 800)	(Below 300)	(Below 400)	(Below 400)	(Below 300)	(Below 300)	(Below 300)	(Below 300)	(Below 300)	(Below 300)	Corrosion + Scale
	Chloride ion	[mgCl ⁻ /l]	Below 200	Below 50	Below 50	Below 50	Below 50	Below 50	Below 50	Below 50	Below 30	Below 30	Corrosion
	Sulfate ion	[mgSO ₄ ²⁻ /l]	Below 200	Below 50	Below 50	Below 50	Below 50	Below 50	Below 50	Below 50	Below 30	Below 30	Corrosion
	M-alkalinity (pH4.8)	[mgCaCO ₃ /l]	Below 100	Below 50	Below 50	Below 50	Below 50	Below 50	Below 50	Below 50	Below 50	Below 50	Scale
	Total hardness	[mgCaCO ₃ /l]	Below 200	Below 70	Below 70	Below 70	Below 70	Below 70	Below 70	Below 70	Below 70	Below 70	Scale
	Calcium hardness	[mgCaCO ₃ /l]	Below 150	Below 50	Below 50	Below 50	Below 50	Below 50	Below 50	Below 50	Below 50	Below 50	Scale
Silica ion	[mgSiO ₂ /l]	Below 50	Below 30	Below 30	Below 30	Below 30	Below 30	Below 30	Below 30	Below 30	Below 30	Scale	
Items to be referred to	Iron	[mgFe/l]	Below 1.0	Below 0.3	Below 1.0	Below 1.0	Below 0.3	Below 1.0	Below 0.3	Below 1.0	Below 0.3	Below 0.3	Corrosion + Scale
	Copper	[mgCu/l]	Below 0.3	Below 0.1	Below 1.0	Below 1.0	Below 1.0	Below 1.0	Below 0.1	Below 1.0	Below 0.1	Below 0.1	Corrosion
	Sulfite ion	[mgS ²⁻ /l]	Not detectable	Not detectable	Not detectable	Not detectable	Not detectable	Not detectable	Not detectable	Not detectable	Not detectable	Not detectable	Corrosion
	Ammonium ion	[mgNH ₄ ⁺ /l]	Below 1.0	Below 0.1	Below 1.0	Below 1.0	Below 0.1	Below 0.3	Below 0.1	Below 0.1	Below 0.1	Below 0.1	Corrosion
	Remaining chloride	[mgCL/l]	Below 0.3	Below 0.3	Below 0.3	Below 0.3	Below 0.3	Below 0.25	Below 0.3	Below 0.1	Below 0.3	Below 0.3	Corrosion
	Free carbide	[mgCO ₂ /l]	Below 4.0	Below 4.0	Below 4.0	Below 4.0	Below 4.0	Below 0.4	Below 4.0	Below 0.4	Below 4.0	Below 4.0	Corrosion
	Stability index		6.0 ~ 7.0	---	---	---	---	---	---	---	---	---	Corrosion + Scale

NOTES

- Names, definitions and units are according to JIS K 0101. Units and figures between brackets are old units published as reference only.
- In case of using heated water (more than 40°C), corrosion is generally noticeable. Especially when the iron materials is in direct contact with water without any protection shields, it is desirable to give the valid measure for corrosion. E.g. chemical measure.
- In the cooling water using hermetic cooling tower, close circuit water is according to heated water standard, and scattered water is according to cooling water standard.
- Supply water is considered drink water, industrial water and ground water except for genuine water, neutral water and soft water.
- The above mentioned items are representable items in corrosion and scale cases.

OPL_1-2-3-4-5_Rev.00_4

9 Operation range

9 - 1 Operation Range

Water content in cooling circuits

The cooled water distribution circuits should have minimum water content to avoid excessive compressors start and stop. In fact, each time the compressor starts up, an excessive quantity of oil goes from the compressor sump and simultaneously there is a rise in the temperature of the compressor motor's stator due to the inrush current during the start-up. To prevent damage to the compressors, it has been envisaged the application of a device to limit frequent stops and restarts.

During the span of one hour there will be no more than 6 starts of the compressor. The plant side should therefore ensure that the overall water content allows a more constant functioning of the unit and consequently greater environmental comfort. The minimum water content per unit should be calculated using this simplified formula:

For 1 compressor unit

$$M \text{ (liters)} = (0.94 \times \Delta T(^{\circ}\text{C}) + 5.87) \times P(\text{kW})$$

For 2 compressors unit

$$M \text{ (liters)} = (0.1595 \times \Delta T(^{\circ}\text{C}) + 3.0825) \times P(\text{kW})$$

For 3 compressors unit

$$M \text{ (liters)} = (0.0443 \times \Delta T(^{\circ}\text{C}) + 1.6202) \times P(\text{kW})$$

where:

- M minimum water content per unit expressed in litres
- P Cooling Capacity of the unit expressed in kW
- ΔT evaporator entering / leaving water temperature difference expressed in $^{\circ}\text{C}$

This formula is valid for:

- standard microprocessor parameters

For more accurate determination of quantity of water, it is advisable to contact the designer of the plant.

10 Hydraulic performance

10 - 1 Water Pressure Drop Curve Evaporator/Condenser

Pressure Drops

EWLD~I-SS

Size	320	400	420	500	600	650	750	800	850	900	950	C10	C11	C12	C13	C14	C15	C16	C17
Cooling Capacity (kW)	328	391	428	504	596	657	730	788	850	919	966	1033	1078	1125	1188	1267	1319	1370	1422
Water Flow (l/s) - Evaporator	15.67	18.68	20.45	24.08	28.48	31.39	34.88	37.65	40.61	43.91	46.15	49.35	51.50	53.75	56.76	60.53	63.02	65.46	67.94
Evaporator Pressure Drops (kPa)	34	47	47	54	49	39	52	47	47	45	45	52	46	49	41	51	55	59	63

Water flow and pressure drop referred to nominal condition: evaporator water in/out: 12/7°C - saturated discharge temperature: 45°C

EPD_1-2_Rev.00_1

Evaporator and Condenser Pressure Drops

To determine the evaporator or condenser pressure drop for different versions or at different working conditions, please refer to the following formula:

$$PD_2 \text{ (kPa)} = PD_1 \text{ (kPa)} \times \left(\frac{Q_2 \text{ (l/s)}}{Q_1 \text{ (l/s)}} \right)^{1.8}$$

where:

- PD₂ Pressure drop to be determined (kPa)
- PD₁ Pressure drop at nominal condition (kPa)
- Q₂ water flow at new working condition (l/s)
- Q₁ water flow at nominal condition (l/s)

How to use the formula: Example (evaporator)

The unit EWLD320I-SS has been selected for working at the following conditions:

- Evaporator water in/out: 11/6°C
- Saturated discharge Temperature: 40°C
- The cooling capacity at these working conditions is: 333 kW
- The evaporator water flow at these working conditions is: 15.91 l/s

The unit EWLD320I-SS at nominal working conditions has the following data:

- evaporator water in/out: 12/7°C
- Saturated discharge Temperature: 45°C
- The cooling capacity at these working conditions is: 328 kW
- The evaporator water flow at these working conditions is: 15.67 l/s
- The evaporator pressure drop at these working conditions is: 34 kPa

The evaporator pressure drop at the selected working condition will be:

$$PD_2 \text{ (kPa)} = 34 \text{ (kPa)} \times \left(\frac{15.91 \text{ (l/s)}}{15.67 \text{ (l/s)}} \right)^{1.8}$$

$$PD_2 \text{ (kPa)} = 35 \text{ (kPa)}$$

NOTE - Important

If the calculated evaporator water pressure drop is below 10 kPa or above 100 kPa please contact the factory for dedicated evaporator.

EPD_1-2_Rev.00_2

11 Specification text

11 - 1 Specification text

Technical Specification for Water Cooled Screw Chiller

GENERAL

The water cooled screw chiller will be designed and manufactured in accordance with following European directives:

Construction of pressure vessel	97/23/EC (PED)
Machinery Directive	2006/42/EC
Low Voltage	2006/95/EC
Electromagnetic Compatibility	2004/108/EC
Electrical & Safety codes	EN 60204-1 / EN 60335-2-40
Manufacturing Quality Stds	UNI – EN ISO 9001:2004

The unit will be tested at full load in the factory at the nominal working conditions and water temperatures. Before shipment a full test will be held to avoid any losses.

Chiller will be delivered to the job site completely assembled and charged with right refrigerant and oil quantity. Comply with the manufacturer instructions for rigging and handling equipment.

The unit will be able to start up and operate as standard at full load and condenser entering fluid temperature from °C to °C with an evaporator leaving fluid temperature between °C and °C

All units published performances have to be certified by **Eurovent**.

REFRIGERANT

Only R-134a will be accepted.

PERFORMANCE

- ✓ Number of water cooled screw chiller:
- ✓ Cooling capacity for single water cooled screw chiller: kW
- ✓ Power input for single water cooled screw chiller in cooling mode: kW
- ✓ Shell & tube evaporator entering water temperature in cooling mode: °C
- ✓ Shell & tube evaporator leaving water temperature in cooling mode: °C
- ✓ Shell & tube evaporator water flow: l/s
- ✓ Saturated Discharge Temperature: °C
- ✓ The unit should work with electricity in range 400V ±10%, 3ph, 50Hz without neutral and shall only have one power connection point.

UNIT DESCRIPTION

Chiller shall include as standard: 1, 2 or 3 independent refrigerant circuits, semi-hermetic rotary single screw compressors, electronic expansion device (EEXV), refrigerant direct expansion shell & tube heat exchangers, R134a refrigerant, lubrication system, motor starting components, control system and all components necessary for safe and stable unit operation. Chiller will be factory assembled on a robust base-frame made of zinc coated steel, protected by an epoxy paint.

NOISE LEVEL AND VIBRATIONS

Sound pressure level at 1 meter distance in free field, semispheric conditions, shall not exceeddB(A). The sound pressure levels must be rated in accordance to ISO 3744.

Other types of rating unacceptable. Vibration level should not exceed 2 mm/s.

DIMENSIONS

Unit dimensions shall not exceed following indications:

- ✓ unit length mm,
- ✓ unit width mm,
- ✓ unit height mm.

11 Specification text

11 - 1 Specification text

CHILLER COMPONENTS

Compressors

- ✓ Semi-hermetic, single-screw type with one main helical rotor meshing with gaterotor. The gaterotor will be constructed of a carbon impregnated engineered composite material. The gaterotor supports will be constructed of cast iron.
- ✓ The oil injection shall be used in order to get high EER (Energy Efficiency Ratio) also at high condensing pressure and low sound pressure levels in each load condition.
- ✓ Refrigerant system differential pressure shall provide oil flow through service replacable, 0.5 micron, full flow, cartridge type oil filter internal to compressor.
- ✓ Refrigerant system differential pressure shall provide oil injection on all moving compressor parts to correctly lubricate them. Electrical oil pump lubricating system is not acceptable.
- ✓ The compressor's oil cooling must be realized, when necessary, by refrigerant liquid injection. External dedicated heat exchanger and additional piping to carry the oil from the compressor to heat exchanger and viceversa will be not accepted.
- ✓ The compressor shall be provided with an external, high efficiency, cyclonic type oil separator and with built-in oil filter, cartridge type.
- ✓ The compressor shall be direct electrical driven, without gear transmission between the screw and the electrical motor.
- ✓ Shall be present two thermal protection realized by a thermistor for high temperature protection: one temperature sensor to protect electrical motor and another sensor to protect unit and lubricating oil from high discharge gas temperature.
- ✓ The compressor shall be equipped with an electric oil-crankcase heater.
- ✓ Compressor shall be fully field serviceable. Compressor that must be removed and returned to the factory for service shall be unacceptable.

Cooling capacity control system

- ✓ Each unit will have a microprocessor for the control of compressor slide valve's position and the instantaneous RPM value of the motor.
- ✓ The unit capacity control shall be infinitely modulating, from 100% down to 25% for each circuit (from 100% down to 12.5% of full load for unit with 2 compressors and 8.3% for units with 3 compressors). The chiller shall be capable of stable operation to a minimum of 12.5% of full load without hot gas bypass.
- ✓ Step unloading unacceptable because of evaporator leaving water temperature fluctuation and low unit efficiency at partial load.
- ✓ The system shall stage the unit based on the leaving evaporator water temperature that shall be controlled by a PID (Proportional Integral Derivative) loop.
- ✓ Unit control logic shall manage frequency level of the compressor electric motor to exactly match plant load request in order to keep constant the set point for delivered chilled water temperature. In this operating condition unit control logic shall modulate electrical frequency level in a range lower and upper the nominal electrical network value fixed at 50 Hz.
- ✓ The microprocessor unit control shall detect conditions that approach protective limits and take self-corrective action prior to an alarm occurring. The system shall automatically reduce chiller capacity when any of the following parameters are outside their normal operating range:
 - o High condenser pressure
 - o Low evaporation refrigerant temperature
 - o High compressor motor amps

Evaporator

- ✓ The units shall be supplied with shell and tubes counter-flow heat exchanger with single refrigerant pass. It will be refrigerant direct expansion type with refrigerant inside the tubes and water outside (shell side). It will include carbon steel tube sheets, with straight copper tubes internally wound for higher efficiencies, expanded on the tube plates.
- ✓ The evaporator will have 2 circuits, one for each compressor and shall be single refrigerant pass.
- ✓ The water connections shall be VICTAULIC type connections as standard to ensure quick mechanical disconnection between the unit and the hydronic network.
- ✓ Evaporator is manufactured in accordance to PED approval.

11 Specification text

11 - 1 Specification text

Refrigerant circuit

Each circuit shall include as standard: electronic expansion device piloted by unit's microprocessor control, compressor discharge shut-off valve, suction line shut-off valve, replaceable core filter-drier, sight glass with moisture indicator and insulated suction line.

Control panel

- ✓ Field power connection, control interlock terminals, and unit control system should be centrally located in an electric panel (IP 54). Power and starting controls should be separate from safety and operating controls in different compartments of the same panel.
- ✓ Starting shall be Wye-Delta type as standard.
- ✓ Operating and safety controls should include energy saving control; emergency stop switch; overload protection for compressor motor; high and low pressure cut-out switch (for each refrigerant circuit); anti-freeze thermostat; cut-out switch for each compressor.
- ✓ All of the information regarding the unit will be reported on a display and with the internal built-in calendar and clock that will switch the unit ON/OFF during day time all year long.
- ✓ The following features and functions shall be included:
 - resetting chilled water temperature by controlling the return water temperature or by a remote 4-20 mA DC signal or by controlling the external ambient temperature;
 - soft load function to prevent the system from operating at full load during the chilled fluid pulldown period;
 - password protection of critical parameters of control;
 - start-to-start and stop-to-start timers to provide minimum compressor off-time with maximum motor protection;
 - communication capability with a PC or remote monitoring;
 - discharge pressure control through intelligent cycling of condenser fans;
 - lead-lag selection by manual or automatically by circuit run hours;
 - double set point for brine unit version;
 - scheduling via internal time clock to allow programming of a yearly start-stop schedule accommodating weekends and holidays.

Optional High Level Communications Interface

The controller as a minimum shall be capable of providing the data shown in the above list, using the following options:

- RS485 Serial card
- RS232 Serial card
- LonWorks interface to FTT10A Transceiver.
- Bacnet Compatible
- Use of Compass Points (manufactured by North Communications) to allow communications with such as Honeywell, Satchwell, Johnson Controls, Trend etc.



A posição única da Daikin como fabricante de equipamento de ar condicionado, compressores e refrigerantes levou a que se envolvesse de perto nas questões ambientais. Há vários anos que a Daikin tem a intenção de se tornar um líder no fornecimento de produtos com impacto limitado no ambiente. Este desafio obriga a uma concepção ecológica e ao desenvolvimento de uma vasta gama de produtos e de um sistema de gestão de energia, resultando na conservação de energia e redução de desperdícios.



O presente folheto pretende ser apenas informativo e não constitui uma oferta contratual com a Daikin Europe N.V. A Daikin Europe N.V. compilou o conteúdo deste folheto de acordo com o melhor dos seus conhecimentos. Não é dada qualquer garantia expressa ou implícita no que toca à totalidade, precisão, fiabilidade ou adequação para um determinado fim do seu conteúdo e dos produtos e serviços que apresenta. As especificações estão sujeitas a alterações sem aviso prévio. A Daikin Europe N.V. rejeita explicitamente quaisquer danos directos ou indirectos, no seu sentido mais amplo, resultantes ou relacionados com a utilização e/ou interpretação deste folheto. Todos os conteúdos estão ao abrigo de copyright da Daikin Europe N.V.

Os produtos Daikin são distribuídos por:



A Daikin Europe N.V. participa no Programa de Certificação Eurovent para Sistemas de Ar Condicionado (AC), Conjuntos de Chillers Líquidos (LCP) e Unidades Ventilador-convectoras (FC); os dados certificados dos modelos certificados são indicados no Directório Eurovent. As unidades múltiplas apresentam o selo Eurovent para combinações até 2 unidades interiores.

